



Pressurized Bead Filters Installation Instructions

Table of Contents

- Safety Information
- Installation
- Assembly
- Start Up
- Maintenance
- Troubleshooting
- Warranty



SAFETY INFORMATION

1. Installation should be made by qualified authorized persons and those who have carefully read the following instructions.
2. Operating safety of the filter is maintained only if installation and operation instructions are correctly followed.
3. To reduce the risk of injury, do not permit children to use this product unless they are closely supervised at all times.
4. Incorrectly installed equipment may fail causing severe injury or property damage.
5. In the event of a defective part or operation, contact the manufacturer.

**CAUTION: READ ALL INSTRUCTIONS BEFORE
BEGINNING INSTALLATION OR OPERATION!**

INSTALLATION

The placement of the filter is important for proper operation and filtration.

BASIC FILTER SET-UP

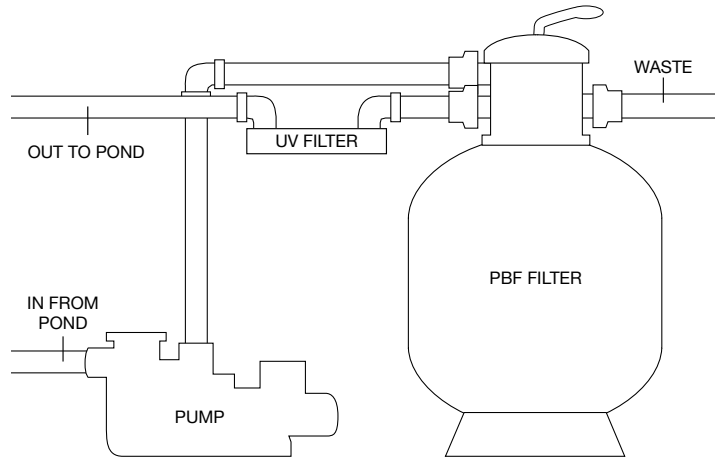

GENERAL THINGS TO CONSIDER FOR INSTALLATION

(Figure 1)

1. If the filter is placed in a room there should be a drain system in the room in case of failure or breakage of plumbing as well as adequate ventilation for pumping equipment.
2. If the system is installed below pond level it is important to install isolating valves to prevent risk of flooding.
3. The filter, pump, plumbing and UV should have adequate space around it for ease of maintenance and service with unit label facing the front to allow identification in case of service difficulties.
4. Plastic fittings should be used for all plumbing connections.
5. Install the filter as close to the pump as possible. Use correctly sized plumbing to minimize friction loss and maximize efficiency.

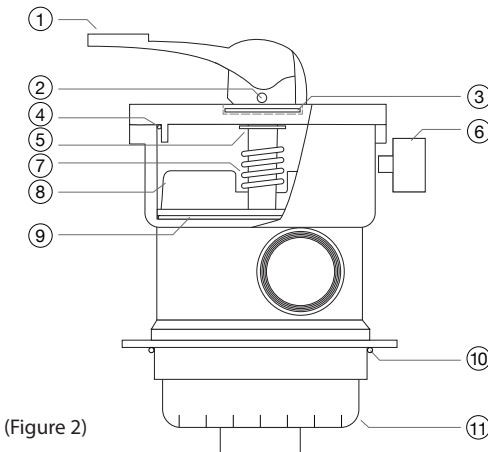

(Figure 2)

Control Valve:

1. Handle
2. Handle Pin
3. Washer
4. Cover O-ring
5. Washer
6. Pressure Gauge
7. Spring
8. Key/Stem Assembly
9. Spider Gasket
10. Body O-ring
11. Diffuser

ASSEMBLY

Before beginning assembly confirm that all components are accounted for and in good condition. Do not begin assembly if parts are missing or components are damaged. Contact EasyPro® if items are missing or damaged.

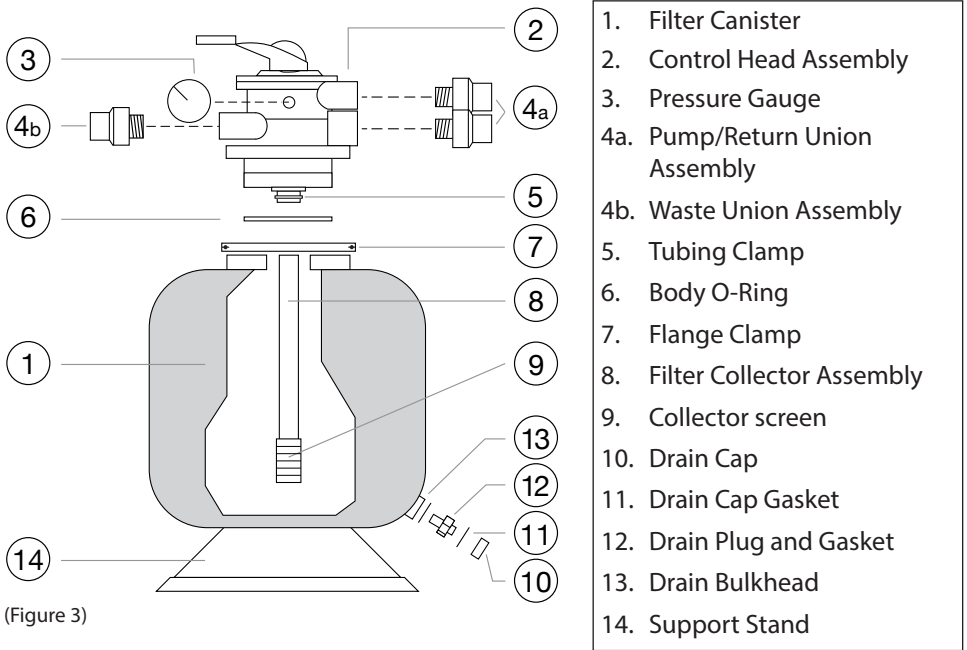

1. Ensure that the surface below the filter is sturdy, clean and level. Filters loaded with water can be several hundred pounds and adequate footing that will not erode is essential.
2. Place the filter body in its final position on the supplied support stand.
3. PBF1800 and PBF3600 models come with media installed and control head pre-assembled.

ADDITIONAL STEPS FOR THE PBF6000 AND PBF10000 UNITS

4. Install provided Ultimate Tube Media into filter body.
5. Place supplied pipe clamp loosely around bottom of control head assembly. Carefully align the bottom of the control head with the collector assembly stand

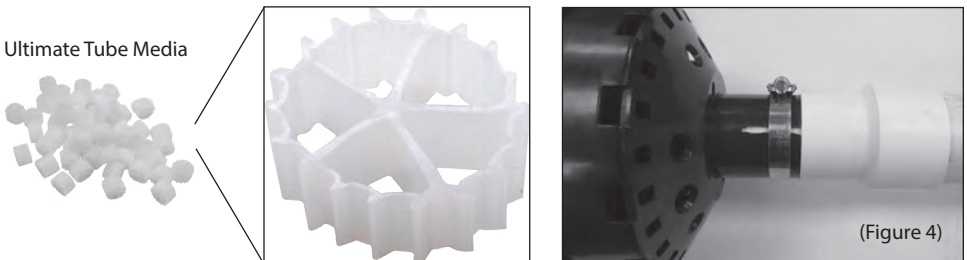

pipe. Insert stand pipe into head until fully seated. Position pipe clamp as shown and tighten until secure.

6. **IMPORTANT:** Fill tank with water. This will allow the media to float and the stand pipe to be inserted into the tank freely without risk of breakage.
7. Insert newly assembled head and stand pipe into filter tub. Be sure to install with body O-ring in place. Slight side to side action can be used to guide assembly through the beads until head is tight against the filter body. Be sure O-ring remains properly in place.

Note: Do not lubricate O-ring, head or filter body.

8. Once positioned in place, secure the control head onto filter body with flange clamp halves.
9. Tighten the bolts on the flange clamp evenly and alternately to ensure equalized tension necessary for proper sealing. Use a large screw driver and tighten firmly. Be sure to align plumbing ports with appropriate plumbing before final tightening of clamp.

ALL FILTER UNITS

10. Install the pressure gauge using teflon tape on threads. Hand tighten only!
11. Install provided union fittings to pump, return and waste line ports. Use only Teflon tape on threads as other sealing materials (paste, silicone, etc.) will void the warranty.
12. Do not over tighten union fittings. Integrated gaskets ensure a water tight seal. Normally hand tightening with one (1) turn with wrench will provide leak proof connection.
13. Glue appropriate PVC plumbing to "PUMP," "RETURN" and "WASTE" connections.

START UP AND MAINTENANCE

Always turn off the pump before turning the control valve handle!

1. Set the control head setting to "BACKWASH". Make sure backwash line is open.
2. Prime and start pump according to pump instructions.
3. Allow tank to be filled with water. Check for leaks and wait for steady flow.
4. Turn off pump. Rotate control head to "FILTER" and be sure return line is open.
5. Restart pump. Check for leaks and wait for steady flow.
6. Make a note of initial pressure on gauge. Pressure will vary by pond and plumbing layout.

It may take one to three weeks for proper balance to be established in the pond ecosystem if a pond is new or has not had previous filtration. Addition of beneficial bacteria products will help equalize pond ecosystem. If the pond is excessively dirty or green (pea soup), a water change is necessary before starting filter.

BACKWASHING

Getting rid of excess waste that collects in the filter is simple with the handle-operated backwash system. No messy rinsing of pads or emptying of nets is required; only the turn of a handle.

Always turn off the pump before turning the valve handle!

1. Turn off pump. Rotate control head handle to "BACKWASH" setting. Make sure backwash line is open.
2. Turn pump on and backwash for one to two minutes until clear water is visible.
3. Turn off pump. Rotate control head to "RINSE" to clean valve.
4. Turn pump on and rinse until clear water is visible (one to two minutes).
5. Repeat steps 1-4 two more times for a total of three times.
6. Turn off pump. Rotate control head to "FILTER" and restart pump for normal operation.

CLEANING THE CONTROL VALVE

From time to time the control head valve may require cleaning if debris gets caught in various sections of the valve. The handle can be difficult to turn or there may be a leak from the waste port indicating an obstruction in the control head valve.

Always turn off the pump before turning the valve handle!

1. Turn off pump.
2. Rotate handle to "FILTER" (if handle won't move try rinsing grooves on head top).
3. Clean any surface debris from control head top. This may resolve the issue.
4. Unscrew screws from control head top. Take care not to lose parts.
5. Remove head, spring, and valve to expose trapped debris.
6. Rinse area, check for debris caught under spider gasket and reset spider gasket. Replace spider gasket if damaged.
7. Re-install components.
8. Turn on pump. If leak continues call customer service for assistance.

REPLACING ULTIMATE TUBE MEDIA

Ultimate Tube Media provides an incredible 500 square feet of surface area in every cubic foot of media and will last for years. When replacing the media, use these amounts:

PBF1800 0.75 cu. ft.

PBF3600 1.5 cu. ft.

PBF6000 3.0 cu. ft.

PBF10000 4.5 cu. ft.

WINTERIZING

Follow these steps for winterizing your EasyPro pressurized bead filter if the filter and pond are shut down for the winter months in freezing climates.

Always turn off the pump before turning the valve handle!

1. Turn off pump. (It is advisable to follow the "Backwashing" procedure on page 5 before winterizing.)
2. After backwashing, drain filter tank by unscrewing drain cap. Take care not to unscrew entire assembly. Cap should remain off during winter.
3. Rotate control head handle to "WINTER." This will allow water to drain from the valve. Leave valve in this position during the winter.
4. To resume filtration: install drain cap, remove control head, agitate media by carefully stirring it up (take care not to damage collector screen), and reconnect control head and plumbing. Follow "Backwashing" procedure on page 5, then return to regular operation.

CONTROL VALVE SETTINGS

Setting	Description
Filter	Normal pond filtration
Backwash	Cleaning filter by reversing the flow
Rinse	Used after backwash to flush valve
Waste	By-passes filter for pond draining or lowering
Recirculate	By-passes filter for circulating water in pond when medicating
Closed	Shuts off flow from pump
Winter	Drains the valve for winterizing to prevent freezing when filter is not in use

Part Number	Pond Size	Dimensions (dia x ht.)	Inlet/Outlet sizes	Max gpm flow recommended	Max Pressure*
PBF1800	Up to 1800 gal.	16" x 32"	1½"	30	35 psi
PBF3600	Up to 3600 gal.	19" x 37"	1½"	50	35 psi
PBF6000	Up to 6000 gal.	24" x 44"	2"	70	35 psi
PBF10000	Up to 10000 gal.	31" x 51"	2"	90	35 psi

*Test pressure to 50 psi. Maximum operating pressure listed.

TROUBLESHOOTING

Issue	Possible Causes	Solutions
Valve is leaking from the waste port	<ul style="list-style-type: none">• Handle turned while pump on• Debris caught under spider gasket in control head	<ul style="list-style-type: none">• Clean control head valve (see section under Start Up and Maintenance)
Handle is hard to turn	<ul style="list-style-type: none">• Pump is running• Debris in top valve assembly	<ul style="list-style-type: none">• Turn off pump before turning handle• Clean top portion of control head• Clean control head valve (see section under Start Up and Maintenance)
Gauge does not register any pressure	<ul style="list-style-type: none">• Filter is new• Pump is not sized properly	<ul style="list-style-type: none">• Pressure may build as filter is established• Larger pump may be necessary• Some pumps (low pressure) may not register on pressure gauge, proper filtration may still be maintained despite no pressure reading due to low back pressure media used in filter
Water is brown or murky	<ul style="list-style-type: none">• Improper system circulation• Various situational factors: fish load, rain event, etc.	<ul style="list-style-type: none">• Check pump operation• UV unit may be necessary
Media is coming out waste port	<ul style="list-style-type: none">• Internal parts are damaged• Media lodged in standpipe	<ul style="list-style-type: none">• Check internal parts for damage
Slow flow out of filter and backwashing does not improve flow	<ul style="list-style-type: none">• Pump clogged, malfunctioning or undersized• Pump strainer basket full	<ul style="list-style-type: none">• Check pump for clog or malfunction• Check pump sizing chart for appropriate flow rates/pressure• Check pump strainer basket

FAQ'S

When do I need to backwash the filter?

It is recommended to backwash the filter every week. Every pond is different, however, and sometimes it may be necessary to backwash less often or more often. Take notice of the pond conditions and observe how often it will be necessary to backwash your filter.

How much head pressure loss should I account for?

There is approximately 5'-12' of head loss in this filter depending on how dirty the filter is.

Can this be my only filter?

Yes, this filter can be your only filter. Other types of filtration can be used in conjunction with these pressure filters as well. Many pond systems use the mechanical filtration of pond skimmers and strainer baskets on external pumps. UV filtration can also be after the EasyPro™ Pressurized Bead Filter for increased water clarity.

EasyPro Pond Products® Limited Warranty

EasyPro Pond Products ("EasyPro") warrants to the purchaser that this product ("Product") will be free from any mechanical or material defects for a period of **three years** from the date of purchase. Warranty is voided if product damage has been caused by failing to turn off pump when switching valve positions, over tightening of the valve or valve fittings, using sealant other than Teflon tape on the valve, using any lubricant on O-ring under the valve or use of non-OEM EasyPro parts or modification of the product.

This warranty only covers properly installed and maintained Products sold by authorized EasyPro Sellers who are subject to and follow EasyPro's quality control standards. Please note that because EasyPro is unable to control the quality of Products sold by unauthorized sellers, unless otherwise prohibited by law, this warranty does not cover Products purchased from unauthorized sellers.

This warranty does not cover normal wear and tear, nor any deterioration suffered through overloading, improper use, negligence, improper installation, acts of God or accident. Similarly, any modification made by the purchaser to the Product will cause the warranty to be null and void. This warranty does not cover any cost associated with the installation or removal of the Product subject to a warranty claim.

All returned items will be inspected to determine cause of failure before a warranty claim is approved.

The exclusive remedies provided hereunder shall, upon EasyPro's inspection and option, be either repair or replacement of the Product or parts covered under this warranty.

Making a Claim: A Return Authorization ("RA") number must first be obtained by calling EasyPro at 800-448-3873 or via email at warranty@easypro.com. It is the purchaser's responsibility to pay the return shipping charges. Be sure to include the RA number, original receipt (in the form of an invoice or sales receipt), your name, your return address and your phone number inside of the package. No warranty claims will be honored without the original receipt that shows that your purchase was made from an Authorized EasyPro Seller. Ensure the product is properly packaged and insured for the replacement value. Damage due to improper packaging is the responsibility of the sender.

ALL OTHER EXPRESS OR IMPLIED WARRANTIES INCLUDING MERCHANTABILITY OF FITNESS FOR A PARTICULAR PURPOSE ARE HEREBY LIMITED IN DURATION TO THE DURATION OF THE WARRANTY AS DESCRIBED ABOVE. Some States do not allow limitations on how long an implied warranty lasts, so the above limitations may not apply to you.

EasyPro shall not be held liable for any damages caused by defective components or materials of this Product; or for loss incurred because of the interruption of service; or any consequential/incidental damages and expenses arising from the production, sale, use or misuse of this Product. Some States do not allow the exclusion or limitation of incidental or consequential damages, so the above limitation or exclusion may not apply to you.

EasyPro shall not be held liable for any loss of fish, plants or any other livestock as a result of any failure or defect of this Product. This warranty gives you specific legal rights, and you may also have other rights that vary from State to State.



800-448-3873 • Grant, Michigan • www.easypro.com